



PRECISA
INTERNATIONAL

Consumables

GLOSSARY OF STAINS

GLOSSARY of STAINS

Your study and comprehension of the slides in your collection will be enhanced if you know something about the staining methods used in their preparation. The following list includes the most important methods routinely used in histology laboratories. Most of the methods were developed empirically (by trial and error); only a few (e.g., Feulgen, P.A.S.) are truly specific for cell structures.

Hematoxylin and Eosin (H&E): The most common routine staining combination. Hematoxylin is used in combination with metal ions, such as aluminum or iron, to form colored chelate complexes. The ingredients of the stain act as cations and are preferentially bound to acidic (anionic) groups in the tissues. The structures to which hematoxylin binds are termed “basophilic” (base-loving). Hematoxylin stains regions rich in nucleic acids blue. Eosin stains many structures (collagen and some areas of cytoplasm) pink. These areas have been termed “acidophilic” but, more properly, should be called eosinophilic.

Periodic acid-Schiff's (PAS): Leucofuchsin (Schiff reagent) has become one of the most useful of histochemical dyes. It is colorless due to prior reduction of the basic fuchsin; it then may be used under varied conditions to stain compounds that are capable of recolorizing the leucofuchsin by oxidation. It serves as a specific stain for deoxyribonucleic acid after hydrolysis of the tissue section with HCl (Feulgen reaction). More generally, it is employed with the “PAS” reaction after oxidation with periodic acid, which releases aldehyde groups from substances containing a diglycol linkage. Since this group is common to carbohydrates, the PAS reaction is of value in staining glycogen, glycoproteins (e.g., mucus), and proteoglycans.

Masson's Trichrome Stain: A combination of acid fuchsin, orange G and light green. Nuclei appear purple-black, cytoplasm red. Collagen fibers and mucin are green, red blood cells yellow to orange, muscle red. Sometimes hematoxylin is used to reinforce blue staining of nuclei, and Verhoff stain may be added to stain elastic fibers black.

Gomori Trichrome Stain: This is often used for muscle biopsies. The stain consists of chromotrope 2R and Fast Green. It is often counterstained with hematoxylin to show nuclei. Proteinacious structures such as muscle fibers and collagen fibers show up as green, nuclei show up as purple, and lipophilic, membranous structures such as mitochondria, T-tubules and sarcoplasmic bodies show up in red. It can show an increase in mitochondria (certain diseases of muscle). It may also help to identify an increase in collagenous connective tissue fibers, or to differentiate between collagen and smooth muscle fibers.

Silver Salts: Used to impregnate certain delicate structures such as the Golgi apparatus, reticular fibers, neuroglia cells, neurofibrils, etc. There are numerous modifications of the silver method.

Resorcin-Fuchsin (Wright's elastic stain) – Combination of resorcinol and fuchine can be used to stain elastic fibers a dark blue. It is often counterstained with hematoxylin to show nuclei.

GLOSSARY of STAINS

Wright's Blood Stain: Uses alcoholic mixture of eosin and methylene blue to differentiate blood cell types in smears of peripheral blood or bone marrow. Red cells are pink/red, nuclei are dark blue and granules in the cytoplasm of some white blood cells stain differently depending on the cell type (red in eosinophils and blue in basophils, for example)

Giemsa: A combined blood stain, consisting of methylene blue, azure and eosin composition and results are similar to those of Wright's stain. Also useful for staining chromosome spreads (G-banding).

Feulgen Reaction: This is a specific and quantitative reaction for the demonstration of DNA. Hydrolysis with HCl forms aldehyde groups on the DNA sugar (deoxyribose) but not on RNA sugar (ribose). The aldehydes then react with reduced basic fuchsin (Schiff's reagent) to form a characteristic red-blue (magenta) color. The specificity of this stain for DNA can be confirmed by pretreatment of the tissue with DNAase, which depolymerizes DNA and abolishes staining.

Metachromasia: The property of certain biological compounds to change the color of such dyes as toluidine blue or thionine. For example, glycosaminoglycans/proteoglycans found in cartilage matrix and mast cell granules will stain red or violet instead of blue with toluidine blue. The phenomenon is apparently caused by a change in the electronic structure of the dye molecule as it interacts with the electrons of the binding polymer and other dye molecules.

Immunohistochemistry: Binding of specific cell or tissue structures (usually proteins) by an antibody directed against that protein. This antibody is often raised in a species other than the one from which the specimen is taken. For example, antibodies may be developed in rabbits to a protein present in human tissue. There are several methods for visualizing where these antibodies have bound to the tissue. In the example above, other antibodies directed against rabbit proteins that are bound to something that can be visualized (either via fluorescent properties or by chemical reaction) will bind to places in the tissue that contains the protein in question. Therefore, you can see where the protein is distributed in the tissue.

GLOSSARY of STAINS

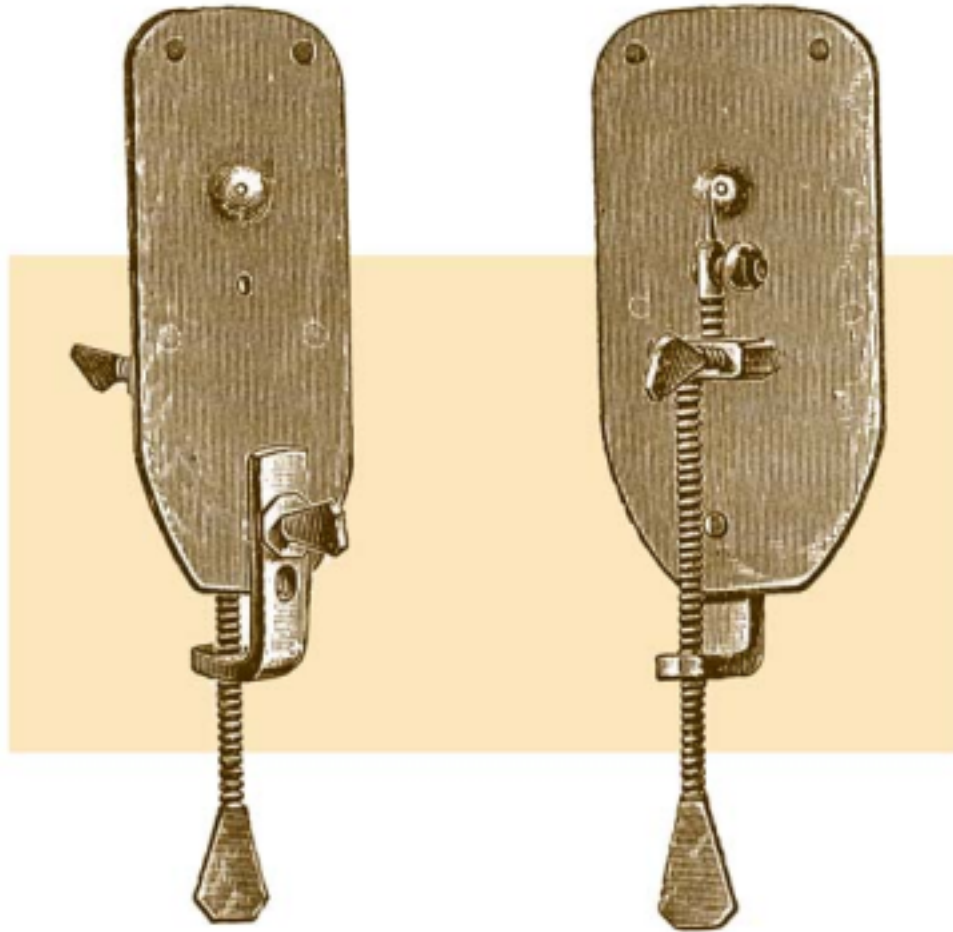

One of the first usable microscopes ever made was this simple instrument by Anton van Leeuwenhoek (1632-1723). Optics consisted of a simple biconvex lens with a 0.25" focus mounted between two plates with a small diameter opening for viewing. The subject to be viewed could be affixed on the pointed shaft on the reverse and positioned with the screws. The microscope was held very close to the eye for viewing. The microscope was quite small and difficult to use. The plates measured about 1.875" in length. Magnification ranges were in the neighborhood of 50-275x. Only nine original Leeuwenhoek microscopes are known to exist.

MICROSCOPIC ANATOMY

As early as you are able, begin to familiarize yourself with the terms describing parts of the microscope and some of the general principles of viewing specimens. This will be reinforced at the first lab, but your experience will be enhanced by some familiarity with these principles of use of the microscope and of microscopic anatomy.

Directions for care of the microscope

Your microscope is a precision instrument and therefore easily damaged by carelessness and rough-handling. Always keep your microscope clean and try to prevent damaging or scratching its parts.

Contamination of the optical elements of the microscope with dust particles, lint or oily smudges is a major problem because lenses function properly only when clean. To avoid such contamination, **always keep your microscope covered when not in use** and try to keep your breath, nose and finger tips away from the surfaces of the lenses. The accumulation of some dust, etc., on the lenses is inevitable. To remove this, *gently* wipe the lens surface with lens paper. (**Important: use only lens paper for wiping lenses;** optical glass is relatively soft and can be scratched easily by wiping with a coarse paper such as a Kleenex or Kimwipes.)

Dust and smudges on the **ocular lens** are visualized as specks which turn when the ocular is rotated with the fingers. Often such contamination is visible by simple inspection of the top lens of the ocular. An ocular should be kept in the body tube at all times to prevent dust from settling on the back lens of the objective.

Dust and smudges on the **objective lens** give a hazy appearance to the image. If necessary, the lower power, dry objectives may be cleaned with a small amount of distilled water applied on lens paper and then gently wiped dry with lens paper. Objectives, particularly the oil immersion one, may occasionally need cleaning with xylene. Only a very small amount of xylene should be used and then promptly wiped off with a clean lens paper. If an excess of xylene is used, the cement mounting of the lenses may be dissolved, thus making it necessary to return the objective to the factory for repair. (Do not use alcohol or other organic solvents for cleaning objectives.)

Use of the light microscope

Simplified directions for the proper use of the compound light microscope are outlined below. These directions should be followed until you are confident that you can make all the indicated adjustments of the microscope from memory.

Note: The following directions are designed especially for students using the rental Olympus binocular microscopes with substage illuminator. Students using other makes and models of microscopes will have to slightly alter the directions to fit their particular equipment. If in doubt, consult an instructor.

- Turn on the substage illuminator and adjust the transformer to a setting of 6 or 7 volts (avoid settings much above 7 volts as this will drastically shorten the life of the lamp filament). Familiarize yourself with the location and operation of the **condenser, focus controls (fine and coarse)** and the lever for adjusting the **aperture of the substage iris diaphragm**. Without a slide on the stage, note the location of the knobs that move the condenser and the stage. Also note that one of the oculars has an adjustment that allows it to be independently focused (this is in order to permit adjustment for disparities in focus of your two eyes).
- Next, rotate the 10X objective into position and raise the stage (coarse focus control) to within a few centimeters of the objective. Place a clean slide from your loan collection (e.g. slide #3) on the stage and visually center the tissue in the slide over the round opening in the stage (be sure the cover glass of the slide is facing upwards). Adjust the condenser so that its top lens is just below the slide.
- While observing from the side, raise the stage until it is within a few millimeters of the objective. Do not actually touch the slide with the objective as this may damage both the slide and the objective. Now look through the oculars and focus downward (e., lower the stage) until the tissue comes into sharp focus. **Do not focus upward** (e.g., **raise stage**) while looking through oculars: you may inadvertently crush the slide with the objective.
- Remove an ocular, look down the tube, and inspect the back lens of the objective. This will probably appear as a uniformly illuminated circle of light. Now open and close the substage iris diaphragm. A fairly sharp image of the edges of the diaphragm should be visible at the back of the objective.
- When the diaphragm is closed as far as possible its image should lie at the center of the back lens of the objective. Open the iris diaphragm until its image covers about 2/3 or 3/4 of the diameter of the back lens. Then observe the effect of moving the **condenser lens** up and down slowly. With the student type of illuminator it will probably be found that the condenser can be moved several millimeters in either direction without much change in the appearance of the back lens. If it is racked down a considerable distance, however, the lighting of the back lens will become uneven and incomplete. Select a condenser setting that sharpens the image of the edges of the iris diaphragm and an even illumination of the back lens of the objective. This is the proper position of the condenser. Now replace the ocular. Generally if the condenser is in the right position, there is less glare and better definition of the image. What are the functions of the condenser and the iris diaphragm?
- Now rotate your 40X objective into position and repeat the last two steps. Note that the adjustments of the condenser and the substage iris diaphragm will be different for this objective. With experience, you will be able to optimize the image of your tissue section by adjusting the iris diaphragm and the condenser without removal of the eyepiece for guidance.

Note: It is best to center part of the specimen image in the **low power** (10X) field before shifting to the "**high-dry**" (40X) or **oil immersion** (100X) objectives. Since the lenses of most quality compound microscopes are manufactured to be **parfocal**, the specimen will remain in fairly good focus when switching back and forth between objectives. A sharply focused image can usually be achieved by slowly rotating the fine focus knob clockwise or counterclockwise, a fraction of a turn. Avoid making major movements of the stage when under high power. It is easy to damage the lens or the microscope slide.

The working distance for the 40X objective is less than 0.5 mm from the specimen. THE 40X OBJECTIVE MUST NEVER TOUCH OIL, WATER, OR THE SPECIMEN. (It will be impossible to obtain a clear image if it does.) If you accidentally get oil on your 40X objective, be sure to clean it promptly with a small amount of xylene, which you then wipe dry with lens paper.

Use of the oil immersion (100X) objective:

Use this objective is necessary only when the finest details of the tissue section are to be studied. Most details can be adequately viewed under the 40X objective. You will be instructed when it is necessary to view a slide under 100X. If you have time, you may practice using the oil immersion lens as follows:

1. Position the focused image of your specimen in the center of the field of the 40X objective.
2. Rotate the "high-dry" (40X) objective out of the way.
3. Place a small drop of immersion oil on the area that you wish to study.
4. While observing from the side slowly rotate the oil immersion objective into position. **(The objective should touch the oil droplet, but should not contact the slide.)**
5. Observe specimen through oculars. If the objectives of your microscope are near parfocal, usually only a little careful **FINE** focusing will be needed to obtain a clear image. If no image is visible when you switch to oil immersion by the initial procedure, move the stage upward slowly using the fine focus adjustment knob so that the 100X objective is closer to the specimen. **WATCH THE APPROACH OF THE TWO FROM THE SIDE. YOU MUST AVOID RAMMING THE SLIDE INTO THE LENS.**
6. Adjust your condenser focus and aperture for optimum illumination.
7. After using the oil immersion objective, be certain to: **1) wipe all the oil off the lens with LENS PAPER, and 2) wipe the oil off your slide with a Kim-wipe moistened with xylene.**

If you are having difficulty using the above procedure, please read the following. (It won't hurt to read this even if you are not having any difficulty!):

- Before using the oil immersion (100X) objective, position the image of your specimen in the center of the field of the 40X objective.
- Clean the 100X objective lens with lens paper. (It is a good idea to clean the lens each time you look at a new slide.)
- The lens of the 100X objective should always be immersed in oil, but should not touch the slide.
- When using the oil immersion lens, you must position the condenser just below the slide by using its condenser focus control. When the condenser almost touches the bottom of the slide, all the light will be focused on a very small area of the specimen so that most of the light enters the extremely small 100X objective lens. If you do not have the condenser raised, the light will hit a much larger area of the specimen and relatively little light from the specimen will enter objective lens. The result is a very dim image and a reduction in your ability to see detail in the specimen.

Remember, the tip of the lens should be completely in the oil, but should not touch the slide. Make sure you know which way to rotate the fine focus knob so that stage will move toward or away from the lens.

Illustration

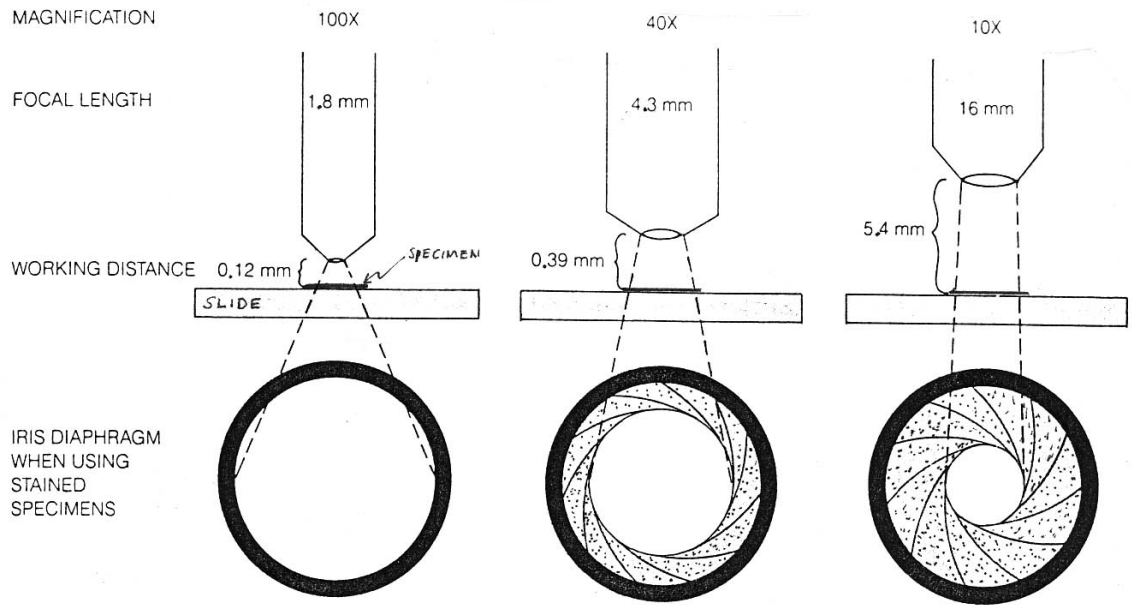

The Relationship between the Working Distance of an Objective Lens and the Adjustment of the Iris Diaphragm

GENERAL DIRECTIONS FOR THE STUDY OF HISTOLOGIC SLIDES

Procedure for slide study

Many students make the mistake of beginning the study of a slide with their highest power objective. The line of thought goes that the greater the magnifying power of the objective, the greater its value for examining sections of tissues. Such an assumption invariably leads to the “can’t see the forest for the trees” syndrome. Actually, a much better orientation and understanding of a tissue section can be obtained by studying it in sequence with the lowest to the highest power objectives. The following routine for examining a slide is recommended:

- Hold the slide to be studied up to light to obtain some idea of the relationship between the gross and microscopic structure of the tissue. Remember An ocular from the microscope makes a handy magnifying glass for a very low power look at the specimen. Simply place the top lens against the slide and look through the bottom of the ocular while holding the slide up to the light. Slowly move the lens away from the slide to focus)
- Next, place the slide on the stage of the microscope and examine it with your lowest power (usually 4X) scanning lens to obtain an overall low magnification impression of the tissue. You can often pick out areas of interest that should be explored at higher power.
- Finally, study the slide in sequence with your 10X & 40X objectives to complete your microscopic picture of the tissue.
- **Do not use the oil immersion (100X) objective routinely.** Only occasionally will it be worthwhile to study a particular feature of a cell or tissue at the highest possible magnification.

Ocular pointer

Frequently, it will be necessary to indicate to your lab instructor a certain cell or cell structure which you find difficult to interpret. For this, it is essential to have a pointer in one of your oculars. If your microscope does not have an ocular pointer, please inform an instructor.

The third dimension

One of the objectives of the laboratory work in microscopic anatomy is for you to acquire a three-dimensional concept of the structure of cells, tissues, and/or organs. This skill is also critical to understanding of other aspects of medicine, especially radiology. You should develop the habit of mentally reconstructing in three dimensions the structures that you see essentially in two dimensions under your microscope. The following diagrams may be of help to you in this regard.

Third Dimension Extrapolation from Microscopic Sections

1.

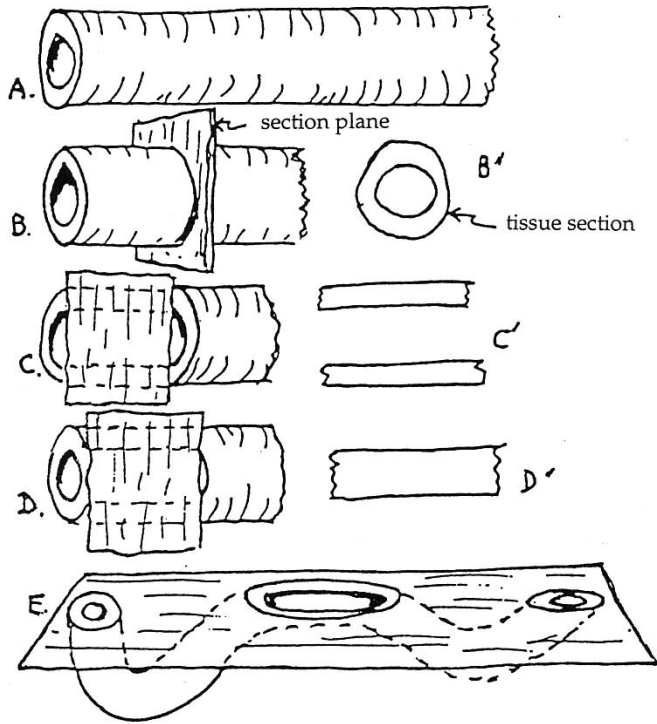

Variations in appearance of sections cut through a tubular structure.

2.

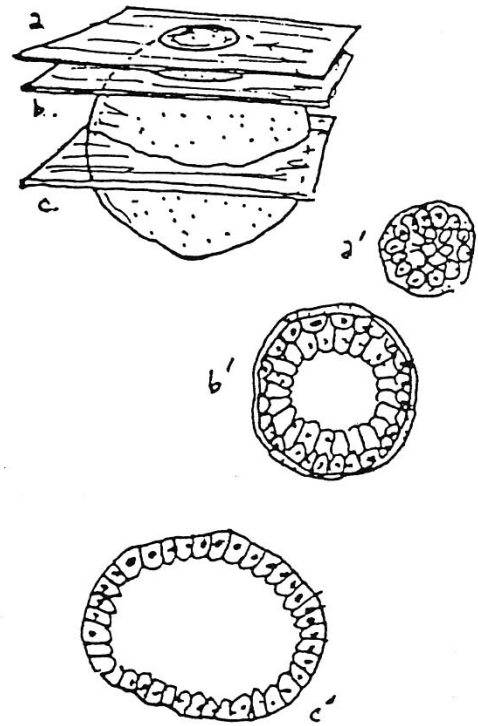

Appearance of sections cut from a hollow ball (cyst) of cells.

Appearance of sections cut in various planes from an egg-shaped nucleated cell.

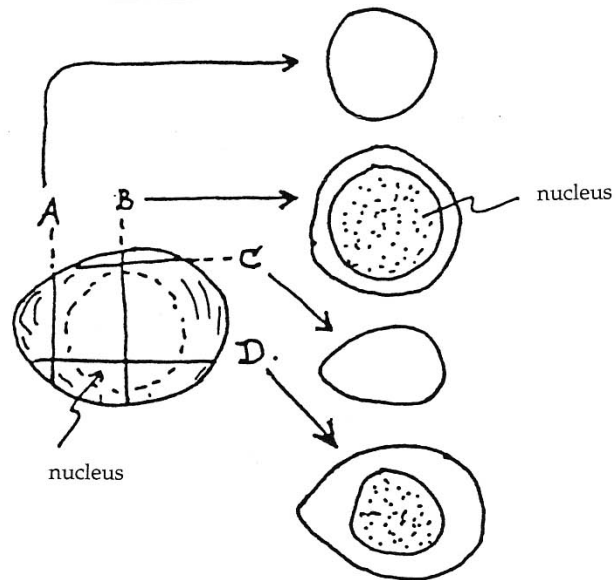

Image Inversion, Field Diameter and Magnification

Using your 4X objective focus on the “CM” printed on Slide #1 (micro test slide):

- Is the CM “right side up” or “upside down” (inverted)? Is the orientation of the CM normal or reversed (rotated 180°)?
- Now orient the slide so that the millimeter divisions of the scale are in view. How many millimeters across is your field of view (illuminated circular viewing area) with the 4X objective? Repeat the process using your 10X and 40X objectives.

Field diameter of:

4X objective = ___ mm?
10X objective = ___ mm?
40X objective = ___ mm?

Magnification.

The magnification obtainable with any of the lens combinations of your microscope is given by the following formula:

Eyepiece (ocular) magnification X Objective (lens) magnification = Total Magnification

Resolving Power

It is not magnification but rather the resolving power of the microscope that is its most important property. Magnification without resolving power (empty magnification) simply yields a blurred image lacking in detail. The “resolving power” of a microscope refers to its capacity to render as distinct images two objects positioned very closely together. The minimum distance between two points at which the microscope can still distinguish the two points is the **resolution** (r) of the microscope. Thus, the smaller the value of r , the greater the resolving power of the microscope. The best resolution achievable by a microscope is known as the “**limit of resolution**” and is a function of the wavelength of light used and the light-gathering capacity of the lens (called the numerical aperture). Practically, this is around 0.2-0.3 microns for a light microscope. Why can an electron microscope see objects that are smaller than 0.2 microns?

V. BIOLOGIC DIMENSIONS

(MICROSCOPIC, SUBMICROSCOPIC, MOLECULAR)

CELLS AND VIRUSES

Diameter of giant algae cell	5 mm
Diameter of squid axon	1 mm
Diameter of amoeba	100 μm
Most eukaryotic cells	50 μm
	10 μm
	5 μm
Most prokaryotic cells	1 μm
Largest virus	300 nm
Smallest bacterium	100 nm
Smallest virus	20 nm

1 mm (millimeter)	= 10^{-3}m (meter)
1 μm (micrometer)	= 10^{-6}m (meter)
1 nm (nanometer)	= 10^{-9}m (meter)

ORGANELLES

Diameter of eukaryotic cell nucleus	10 μm
	5 μm
Mitochondrion	1 μm
Condensed chromosome	200 nm
Diameter of ribosome	20 nm

MOLECULES AND ATOMS

Length of collagen molecule	300 nm
Diameter of small protein	4 nm
Diameter of amino acid	0.5 nm
Diameter of carbon atom	0.3 nm

PRELIMINARY CHECK LIST

Be comfortable using your microscope, understanding the function and location of the various knobs:

- condenser
- fine and coarse focus controls
- lever for adjusting the iris diaphragm
- mechanical stage controls
- light intensity control

Know how to obtain the best illumination by having the condenser at the proper height and adjusting the iris diaphragm.

Define the following terms:

- working distance
- field diameter
- resolving power
- millimeter, micrometer, nanometer
- size of average eukaryotic cell
- size range of prokaryotic cell
- size range of viruses
- diameter of erythrocyte (red blood cell)
- diameter (range) of cell nucleus
- diameter of mitochondrion
- diameter of ribosome
- diameter of actin, intermediate filaments, microtubules

Be able to define:

- hematoxylin and eosin (H&E)
- feulgen reaction
- PAS reaction
- silver stains
- basophilia
- acidophilia
- metachromasia
- immunohistochemistry

QUALITY PRODUCTS & SERVICES SINCE 1982

We offer up to date practical solutions for an ever changing medical device industry, with over 36 years of experience in the global markets. We inform. We link. We share in your success. Our goal is to share information on all products used in small to mid-size laboratories. We leverage our buying power and market knowledge to provide affordable, competitive goods to end users as well as distributors.

**TO ORDER PRODUCTS
CALL 305.669.0898
OR EMAIL
sales@PrecisaInternational.com**

A graphic consisting of a series of curved lines that transition from blue on the left to green on the right, creating a sense of motion and depth.

PRECISA
INTERNATIONAL